

ASSEMBLY INSTRUCTIONS

LOFT TABLE

Scope of delivery:

4 x cylinder head screw with hexagon socket M8 x 16 mm, 4 x washer
1 x adjuster for table top, 8 x connecting sleeve M8 x 20 mm
16 x countersunk screw with hexagon socket M8 x 20 mm
2 x Allen key 5 mm

Figure 1:

Place the table upside-down on a level surface. Screw the legs together as shown and slightly tighten the screws. To do this, use:
4 x cylinder head screws with hexagon socket M8 x 16 mm, 4 washers.

Figure 2:

Now screw the adjuster for the table top into the center fixture.

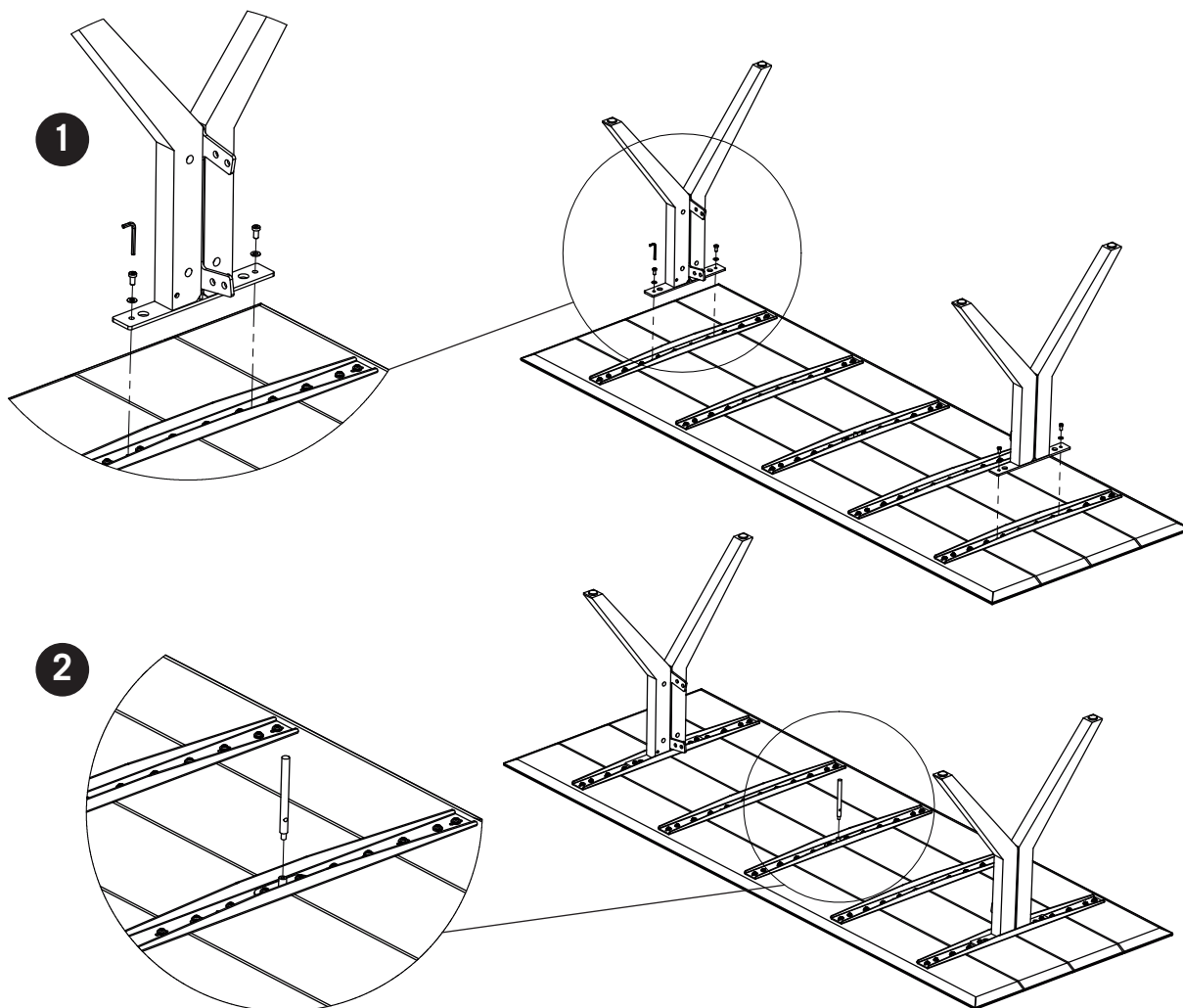

ASSEMBLY INSTRUCTIONS

LOFT TABLE

Figure 3:

Now insert the x-shaped support into the recesses provided for this purpose in the table legs and screw them tight as shown in the diagram.

To do this, use: 8 x connecting sleeve M8 x 20 mm

16 x countersunk screws with hexagon socket M8 x 20 mm

Figure 4:

Check that the adjuster for the table top is in the right position in the x-shaped support (bore hole in the centre of the x). Finally, tighten all screws.

3

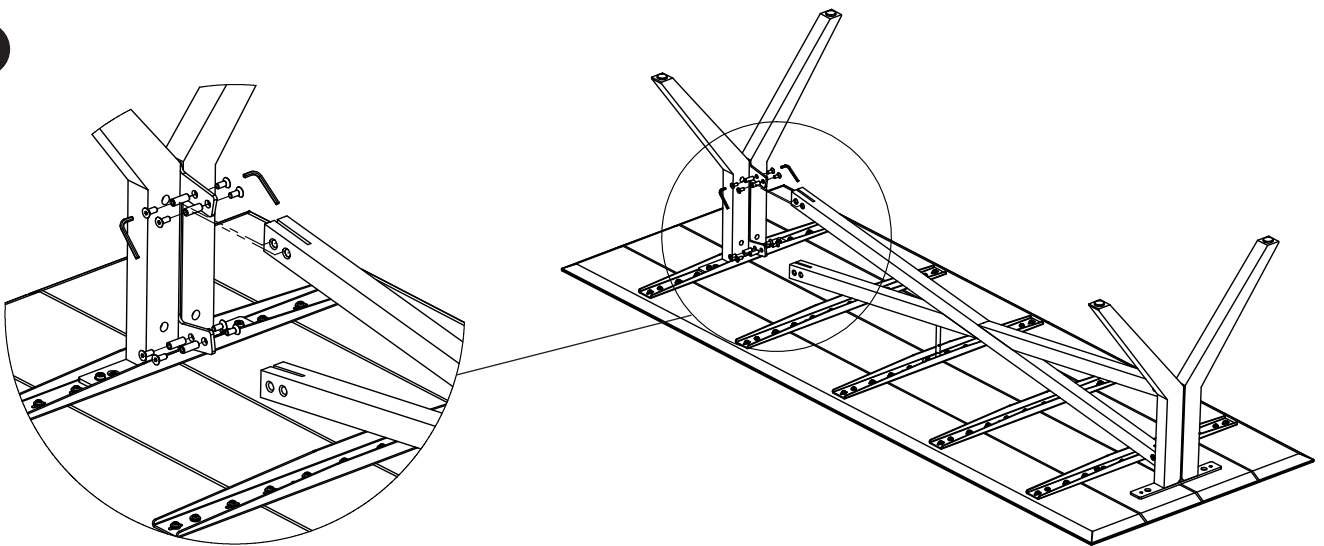

4

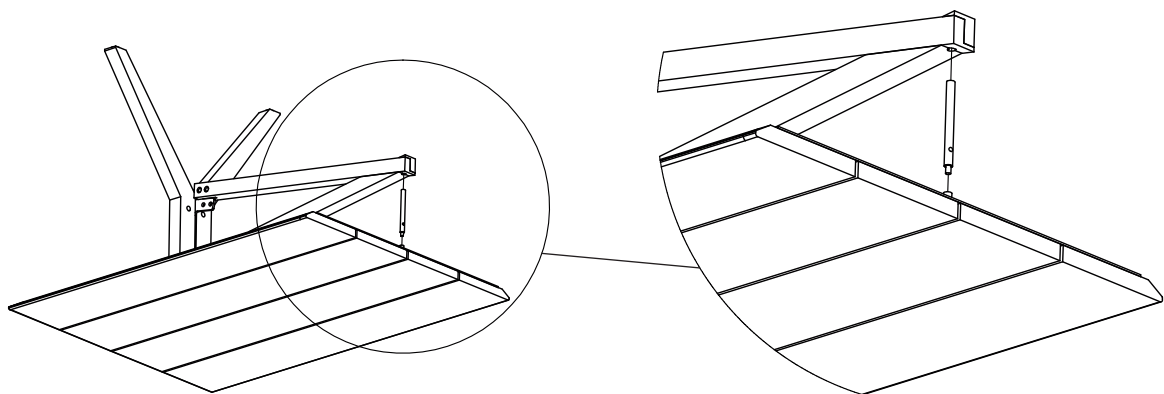

ASSEMBLY INSTRUCTIONS

LOFT TABLE

Figure 5:

The table top can be aligned horizontally using the adjuster.

5

